



## Bronze Relief Valves Dome Top - Screwed or Flanged Connections

<b>Order Ref:</b>	<b>Metal Seat:</b>	<b>G55-M-DN-X</b>
	<b>TFM Seat:</b>	<b>G55-T-DN-X</b>
	<b>Viton Seat:</b>	<b>G55-V-DN-X</b>
	<b>Silicon Seat:</b>	<b>G55-SI-DN-X</b>

*DN = Size in mm*

*X = Spring Range (see Chart Over)*

### GRESSWELL G55 RELIEF VALVES

Side Outlet discharge with leak proof Dome Cover over the adjusting screw. These valves are commonly used for preventing a safe pressure being exceeded in pressurised systems.

The lift is proportional to the system overpressure.

### SIZE RANGE

mm	15	20	25	32	40	50	65	80
ins	1/2	3/4	1	1 1/4	1 1/2	2	2 1/2	3

### PIPE CONNECTIONS

Male Inlet x Female Outlet.

Standard valves are threaded BS 21:1985 Rp Parallel. Alternative thread standards, i.e. taper or NPT are available upon request.

Flanged connections also available. Most flange standards can be accommodated, e.g. ANSI, BS4504 - please specify requirements.

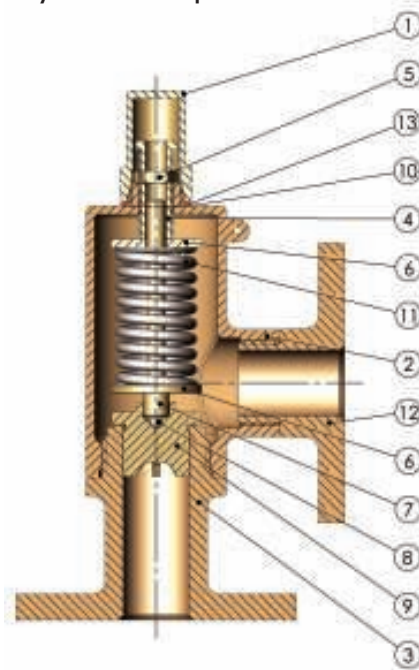

### STANDARD SPECIFICATION

No.	Component	Material	No.	Component	Material
1	Dome Top	Cu Alloy BS EN 12164 CW617N	6	Spring Plate	Cu Alloy BS EN 12164 CW721R
2	Body	Cu Alloy BS EN 1982 CC491K	7	Spindle	Cu Alloy BS EN 12164 CW721R
3	Base (Metal Seat)	Cu Alloy BS EN 1982 CC491K	8	Ball	Chrome Steel AISA 52100
3T	TFM Seat	Dyneon™ TFM™ PTFE 1600	9	Valve	Cu Alloy BS EN 12165 CW602N
3V	Viton Seat	Viton 85 Brown	10	Label	Metallised Polymer
3S	Silicone Seat	Silicone 50 Blue	11	Spring 15 - 50mm	St. Steel BS2056 302 S26
3FL	Flanged Inlet	Cu Alloy BS EN 1982 CC491K		Spring 65 & 80mm	Carbon Steel BS5216 ND3
4	Adjusting Screw	Cu Alloy BS EN 12164 CW641N	12	Flanged Outlet	Cu Alloy BS EN 1982 CC491K
5	Lock Nut	Cu Alloy BS EN 12164 CW641N	13	Washer	Fibre

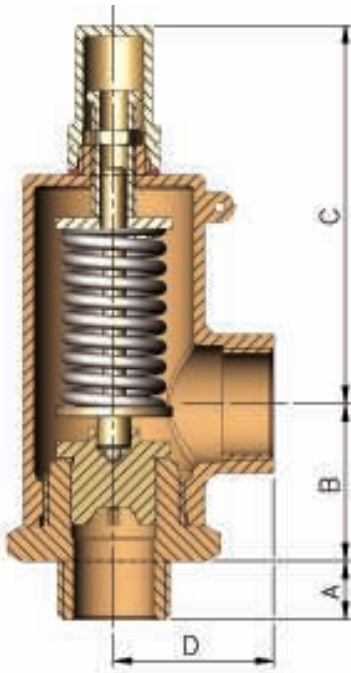

## FEATURES & BENEFITS

Gresswell Valves are quality assurance approved to BS EN ISO 9001: 2000. Certificate No. 0910407.

Full Cat IV PED approval.

Only 4 springs are needed to cover the full pressure range.

Clear operating and maintenance instructions are supplied with each despatch.

Screwed/Flanged or a combination of both are available as standard.

See leaflet Ref: DC G55 & G90 for Discharge Capacities.

## TESTING

All Gresswell Relief Valves are given a hydraulic seat tightness test before leaving the factory and the adjustment range is clearly marked.

All valves are supplied pre-set.

Flanged valves are pressure tested to ensure soundness of joints.

Special tests or witness testing can be arranged at extra cost.

## DIMENSION CHART

Size	A	B	C	D	Weight (kg)
<b>DN15</b>	16	35	87	34	0.6
<b>DN20</b>	16	36	97	40	0.8
<b>DN25</b>	17	47	113	48	1.5
<b>DN32</b>	23	51	136	51	2.0
<b>DN40</b>	24	51	138	56	2.6
<b>DN50</b>	27	60	127	62	3.5
<b>DN65</b>	28	87	156	78	6.9
<b>DN80</b>	28	94	170	83	9.0

All dimensions in millimetres (mm). Flange dimensions vary according to specification (available upon request).

## SEAT TYPES - SPRING/PRESSURE RANGES

Seat Housing	Valve	Pressure Range	Temperature Range	Spring Range (bar & p.s.i.)			
				A (Low)	B (Medium)	C (High)	D (Special)*
Bronze	Bronze	to 20.7 bar (300 p.s.i.)	-15° to +225°C	0.5 - 3.5 (7 - 50)	3.5 - 10.4 (50 - 150)	10.4 - 20.7 (150 - 300)	N/A
Bronze TFM insert	Bronze	to 20.7 bar (300 p.s.i.)	-15° to +225°C	0.5 - 2.0 (7 - 30)	2.0 - 8.3 (30 - 120)	8.3 - 17.9 (120 - 260)	17.9 - 20.7 (260 - 300)
Bronze VITON seal†	Bronze	to 20.7 bar (300 p.s.i.)	-15° to +200°C	0.5 - 2.0 (7 - 30)	2.0 - 8.3 (30 - 120)	8.3 - 16.5 (120 - 240)	16.5 - 20.7 (240 - 300)

\* D spring only available as standard for DN15, DN20, DN25 and DN40 soft seated valves.

† SILICON seal also available on request - available set pressures will be confirmed at time of order. DN65 and DN80 not available.



**GUYSON INTERNATIONAL LIMITED**      **HOSE & COUPLINGS DIVISION**  
 Southview Business Park, Guiseley, Leeds LS20 9PR Tel: 01943 870044 Fax: 01943 870066  
 Email: leeds@guyson.co.uk Web: www.guyson.co.uk



FS 28046