



Bronze Relief Valves Test Lever - Screwed or Flanged Connections

Order Ref:	Metal Seat:	G90-M-DN-X
	TFM Seat:	G90-T-DN-X
	Viton Seat:	G90-V-DN-X
	Silicon Seat:	G90-SI-DN-X

DN = Size in mm

X = Spring Range (see Chart Over)

GRESSWELL G90 RELIEF VALVES

Side Outlet discharge with test lever. These valves are commonly used for preventing a safe pressure being exceeded in pressurised systems.

The lift is proportional to the system overpressure.

SIZE RANGE

mm	15	20	25	32	40	50	65	80
ins	1/2	3/4	1	1 1/4	1 1/2	2	2 1/2	3

PIPE CONNECTIONS

Male Inlet x Female Outlet.

Standard valves are threaded BS 21:1985 Rp Parallel. Alternative thread standards, i.e. taper or NPT are available upon request.

Flanged connections also available. Most flange standards can be accommodated, e.g. ANSI, BS4504 - please specify requirements.

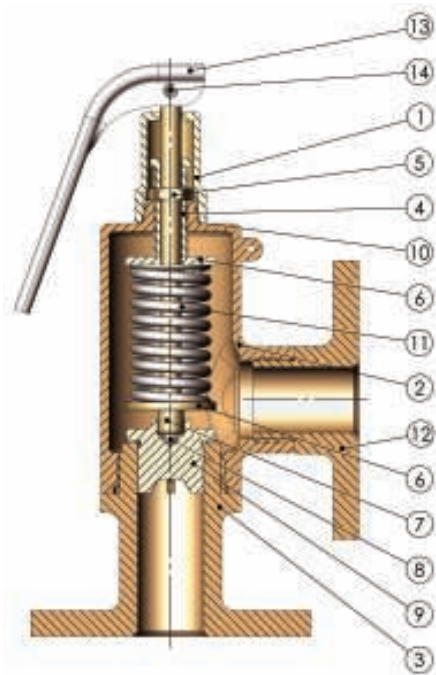

STANDARD SPECIFICATION

No.	Component	Material	No.	Component	Material
1	Dome Top	Cu Alloy BS EN 12164 CW617N	7	Spindle	Cu Alloy BS EN 12164 CW721R
2	Body	Cu Alloy BS EN 1982 CC491K	8	Ball	Chrome Steel AISA 52100
3	Base (Metal Seat)	Cu Alloy BS EN 1982 CC491K	9	Valve	Cu Alloy BS EN 12165 CW602N
3T	TFM Seat	Dyneon™ TFM™ PTFE 1600	10	Label	Metallised Polymer
3V	Viton Seat	Viton 85 Brown	11	Spring 15 - 50mm	St. Steel BS2056 302 S26
3S	Silicone Seat	Silicone 50 Blue		Spring 65 & 80mm	Carbon Steel BS5216 ND3
3FL	Flanged Inlet	Cu Alloy BS EN 1982 CC491K	12	Flanged Outlet	Cu Alloy BS EN 1982 CC491K
4	Adjusting Screw	Cu Alloy BS EN 12164 CW641N	13	Lever	Stainless Steel
5	Lock Nut	Cu Alloy BS EN 12164 CW641N	14	Lever Pin	Stainless Steel
6	Spring Plate	Cu Alloy BS EN 12164 CW721R			

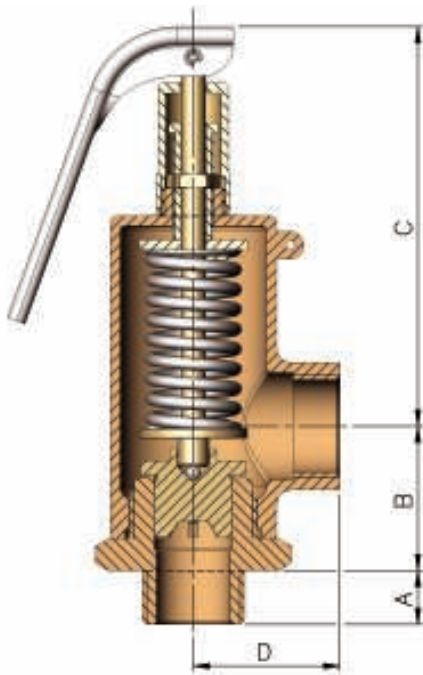

FEATURES & BENEFITS

Gresswell Valves are quality assurance approved to BS EN ISO 9001: 2000. Certificate No. 0910407.

Full Cat IV PED approval.

Only 4 springs are needed to cover the full pressure range.

Clear operating and maintenance instructions are supplied with each despatch.

Screwed/Flanged or a combination of both are available as standard.

See leaflet Ref: DC G55 & G90 for Discharge Capacities.

TESTING

All Gresswell Relief Valves are given a hydraulic seat tightness test before leaving the factory and the adjustment range is clearly marked.

All valves are supplied pre-set.

Flanged valves are pressure tested to ensure soundness of joints.

Special tests or witness testing can be arranged at extra cost.

DIMENSION CHART

Size	A	B	C	D	Weight (kg)
DN15	16	35	104	34	0.6
DN20	16	36	114	40	0.8
DN25	17	47	130	48	1.5
DN32	23	51	155	51	2.0
DN40	24	51	155	56	2.6
DN50	27	60	144	62	3.5
DN65	28	87	167	78	6.9
DN80	28	94	181	83	9.0

All dimensions in millimetres (mm). Flange dimensions vary according to specification (available upon request).

SEAT TYPES - SPRING/PRESSURE RANGES

Seat Housing	Valve	Pressure Range	Temperature Range	Spring Range (bar & p.s.i.)			
				A (Low)	B (Medium)	C (High)	D (Special)*
Bronze	Bronze	to 20.7 bar (300 p.s.i.)	-15° to +225°C	0.5 - 3.5 (7 - 50)	3.5 - 10.4 (50 - 150)	10.4 - 20.7 (150 - 300)	N/A
Bronze TFM insert	Bronze	to 20.7 bar (300 p.s.i.)	-15° to +225°C	0.5 - 2.0 (7 - 30)	2.0 - 8.3 (30 - 120)	8.3 - 17.9 (120 - 260)	17.9 - 20.7 (260 - 300)
Bronze VITON seal†	Bronze	to 20.7 bar (300 p.s.i.)	-15° to +200°C	0.5 - 2.0 (7 - 30)	2.0 - 8.3 (30 - 120)	8.3 - 16.5 (120 - 240)	16.5 - 20.7 (240 - 300)

* D spring only available as standard for DN15, DN20, DN25 and DN40 soft seated valves.

† SILICON seal also available on request - available set pressures will be confirmed at time of order. DN65 and DN80 not available.



GUYSON INTERNATIONAL LIMITED **HOSE & COUPLINGS DIVISION**
 Southview Business Park, Guiseley, Leeds LS20 9PR Tel: 01943 870044 Fax: 01943 870066
 Email: leeds@guyson.co.uk Web: www.guyson.co.uk



FS 28046